

COMPRESSOR SOLUTIONS

HD162-B Base Mounted Unit
driven @ 675 RPM

Gas: Nitrogen
 $n = 1.4$ MW = 28.01

Inlet: 64 psig, 104°F
(4.5 kg/cm²g, 40°C)

Outlet: 120 psig
(8.4 kg/cm²g)

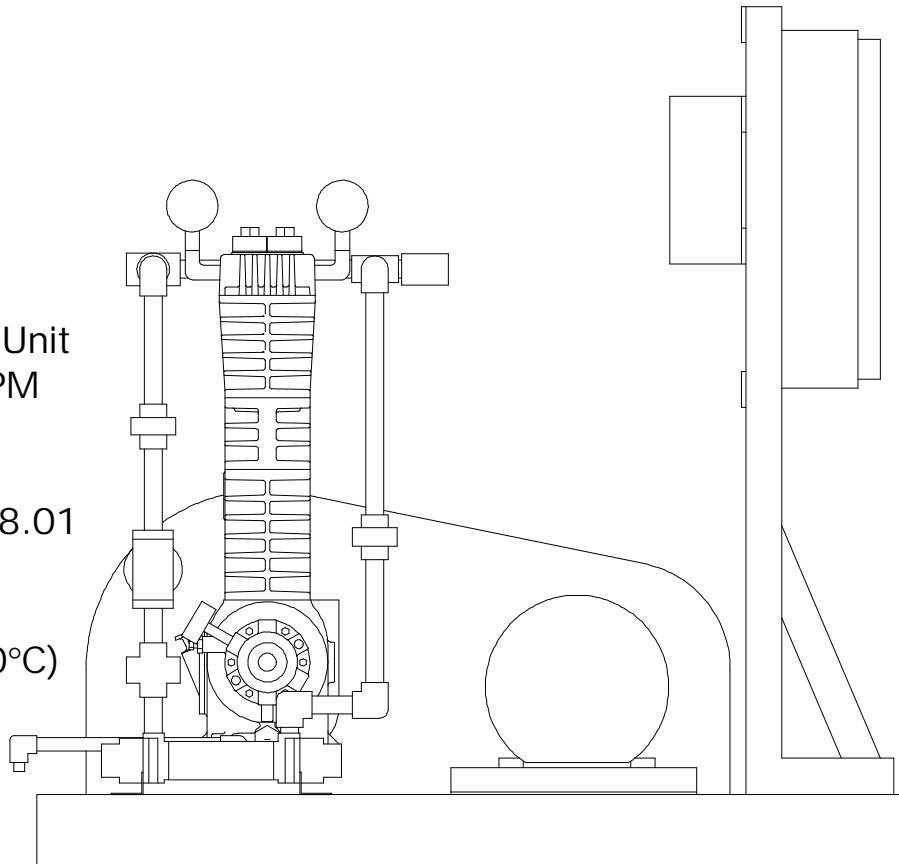

AE90-98759-1 A

Compressor Trim: Buna-N O-rings, Aluminum Gaskets

Accessories:

5 HP Motor, relief valve, water cooled aftercooler, bypass system, control panel with starter, gauges for suction and discharge gas pressures, and crankcase oil pressure gauge.

This nitrogen boost compressor is being used in Seoul, Korea. The control panel actuates the bypass system on rising discharge pressure and starts a countdown timer. If the discharge pressure falls a sufficient amount before the timer times out, the bypass valve is closed and the compressor resumes normal operation. Otherwise, the compressor motor shuts down and will not restart until the discharge pressure falls. Upon restart, the bypass system is actuated for 10 seconds to provide loadless starting. As this unit is being used in a clean system, it was specially cleaned prior to shipment to eliminate all machining oil in the cylinder area. To protect the bare metal in the cleaned cylinder it was shipped with a nitrogen purge to prevent ambient air entry.