

**COMPRESSOR SOLUTIONS**

**LB361-ELU**

Truck Mounted  
LPG Compressor

Gas: Propane  
n=1.13  
MW=44.1

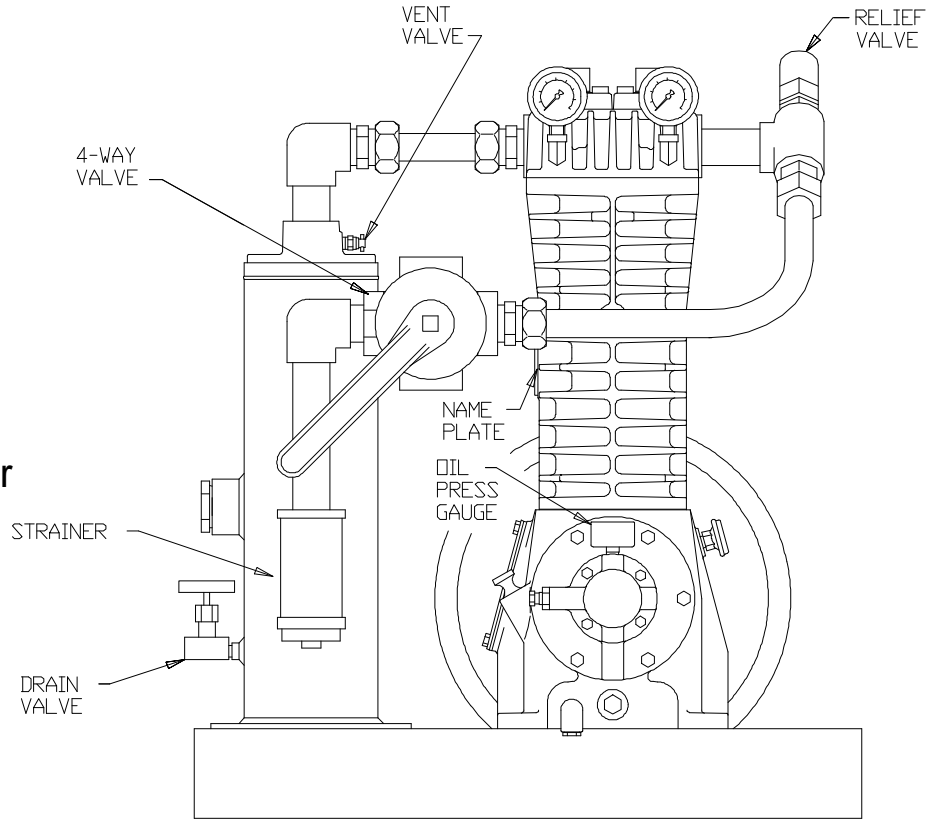

GC1117

Inlet: 63 - 200 psig  
(4.4 - 14.1 kg/cm<sup>2</sup>g)  
Ambient Temperature

Outlet: 75 - 225 psig  
(5.3 - 15.8 kg/cm<sup>2</sup>g)

**COMPRESSOR TRIM and ACCESSORIES**

Ductile Iron Cylinder

Buna-N O-rings

Aluminum Gaskets

Suction Strainer

Discharge Relief Valve

Oil Pressure Gauge

Liquid Trap with  
Mechanical Float

Suction and Discharge  
Pressure Gauges

4-Way Flow Control Valve

**DRIVER**

Blackmer HyDrive or Engine PTO Shaft

This LB361-ELU is fitted on a shortened and specially strengthened baseplate to allow it to be mounted on a truck. Mounting the compressor on the truck allows deliveries to be made to virtually any location as no transfer equipment need be installed at each delivery site. Driven by a Blackmer Hydrive system or the truck's PTO, the LB361 will transfer propane at up to 200 gpm (750 lpm). The same compressor can also be used to empty a 'pup' (a second tank towed behind the delivery truck). After emptying all the liquid propane, the 4-way valve is reversed and the remaining vapors are recovered as well.