

# Crankcase Oil Heater

Part No. 790574

- Crankcase oil heater- All models
- Crankcase Connection: 3/4" NPT
- Electrical Connection: 3/4" NPT Conduit
- Stainless Steel Insertion Shell
- Housing: NEMA 7, Class 1 Group C and D
- Internal Thermostat: Set 70°F (21.1°C) non-adjustable
- 120V. AC operation (60Hz.)
- 110V. AC operation (50Hz.)
- Power rating: 75 Watts at 120V.
- Watt Density: 6 Watts/in<sup>2</sup>

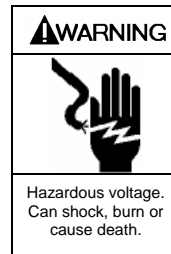
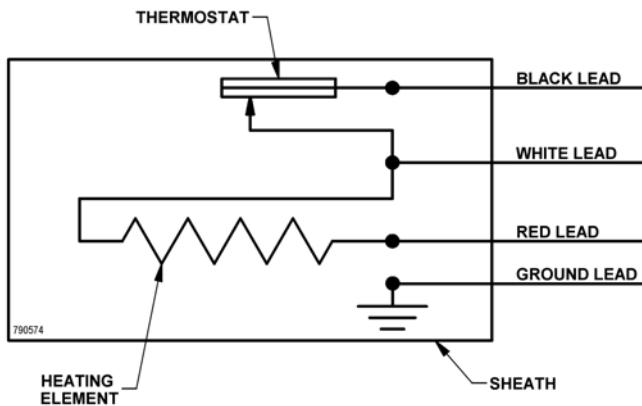
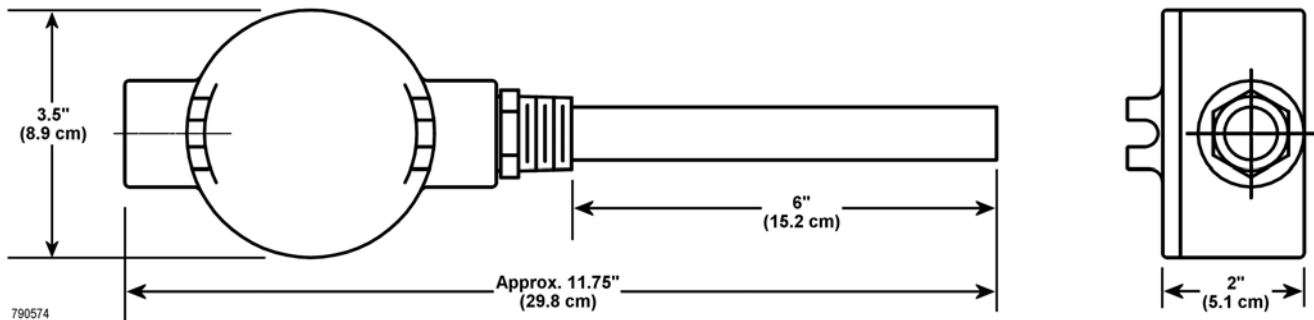

**Failure to disconnect and lockout electrical power before attempting maintenance can cause shock, burns or death**

For aftermarket field installation a 3/4" NPT connection must be added to the crankcase to install the heater assembly. The location of the hole is very important. Contact the factory for correct placement dimensions of the NPT connection.

**Keep crankcase oil level at proper level to prevent damage from overheating.**